

Troubleshooting

Occasionally, some unpredictable situations may occur, such as a foreign object or an unusual bullet position blocking the normal operation of the bullet feeder machine.

In such a case, the motor will shut itself down, but its force may still push the drum around, preventing normal operation even after you clear the obstruction.

In this case, unplug the DC supply and use your finger to push down the notched lever (fig. 13) on the back of the Bullet Feeder and move the motor assembly clockwise (fig. 14) so that the gear on the bottom disengages.

When disengaged, clear any objects blocking the operation. When all appears normal, re-engage the motor and plug back the DC supply.

Additionally, unplugging and re-plugging the power switch may be necessary after such a malfunction (fig. 15).

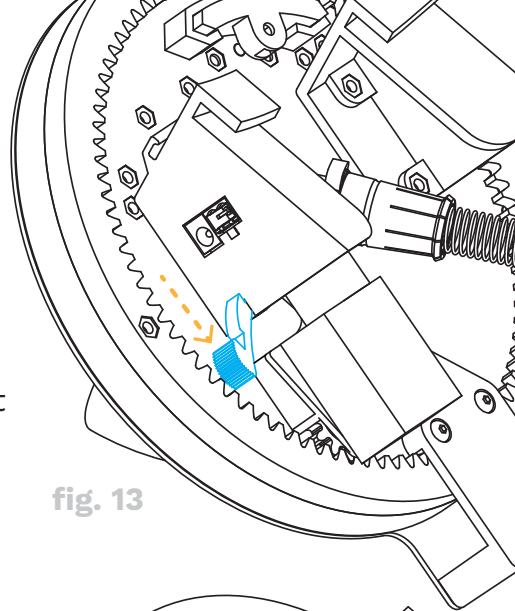

fig. 13

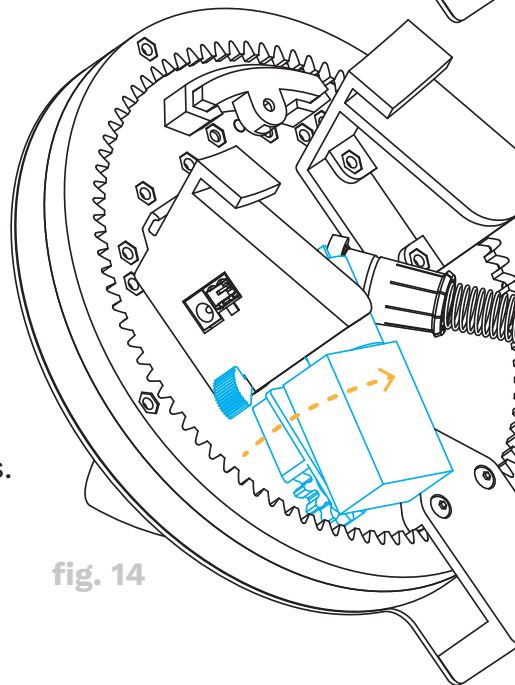
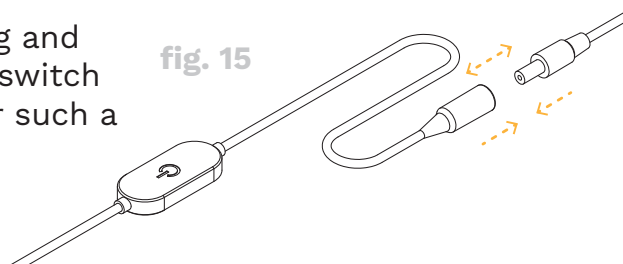

fig. 14

fig. 15



Instructions Manual



Armanov d.o.o.
Dobrave 3
1236 Trzin, Slovenija
Tel: +386 30 467 000
www.armanov.com

Bullet Feeder Placement

Place Bullet feeder on case feeder of machine like shown on fig 1.

fig. 1

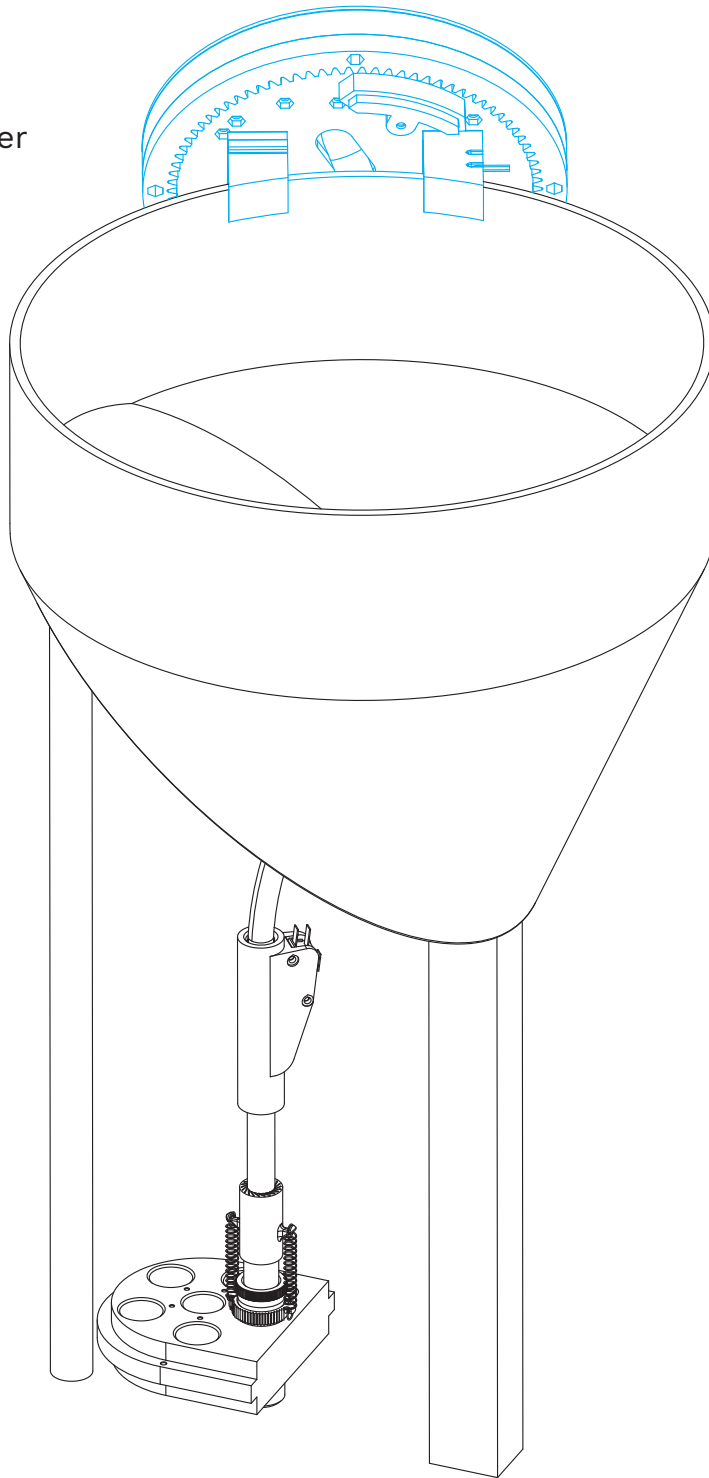

Adjusting movable ramp for correct bullet sorting

Using the hex key you can adjust the width of the ramp depending on the length and shape of the bullets.

Turn the adjustment screw OUT (clockwise) so that correctly oriented bullets will pass over the ramp and incorrectly oriented will fall off the ramp.

If both correctly and incorrectly oriented bullets pass over the ramp, turn screw IN (counterclockwise) until incorrectly oriented bullets will begin falling off the ramp and correctly oriented bullets will pass over the ramp.

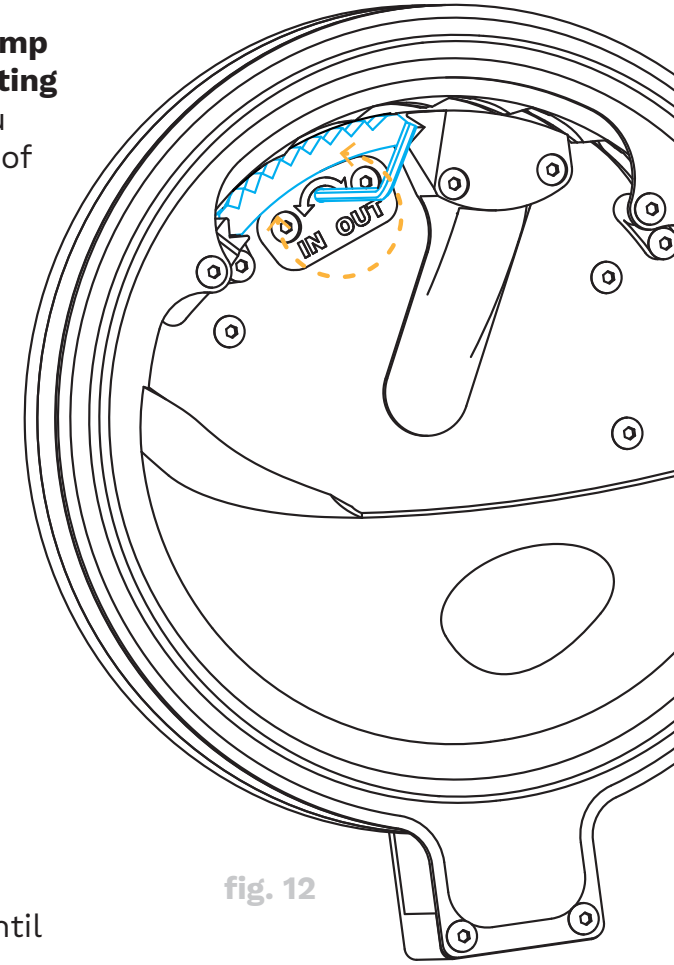
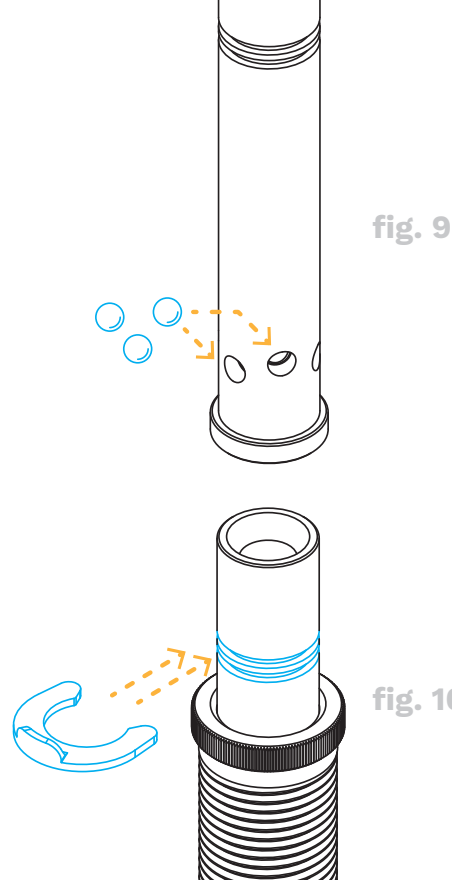

fig. 12

Fine-tuning

Depending on the length and the shape of the bullets you use, you may need to adjust the position of the three beads (inside upper or lower holes, fig. 9) and/or position of the plastic limiter (upper or lower notch, fig. 10).



Beads and limiter settings

There are four possible combinations of beads and limiter positions. The best combination depends on the length and shape of your bullets. Usually, it's easiest to find proper combination using trial and error technique.

fig. 11

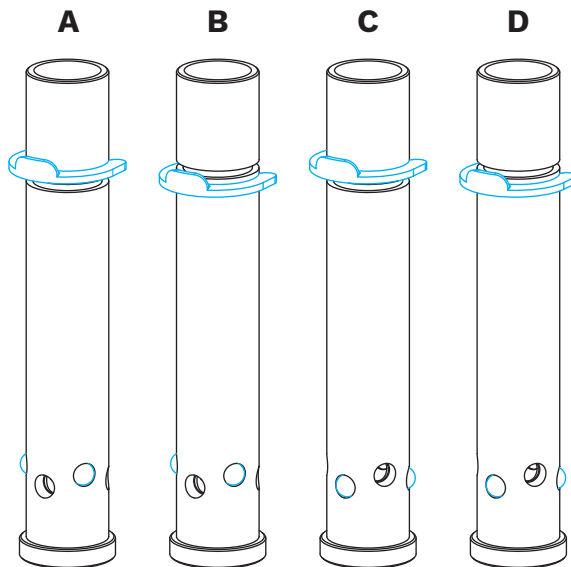

Connect spring adapter to Bullet Feeder assembly

Take the spring adapter and plug it to the tube at the back of the bullet feeder (fig. 2).

Then turn it clockwise (fig. 3) about 1/4 turn to lock it.

Now it's securely locked in place (fig. 4).

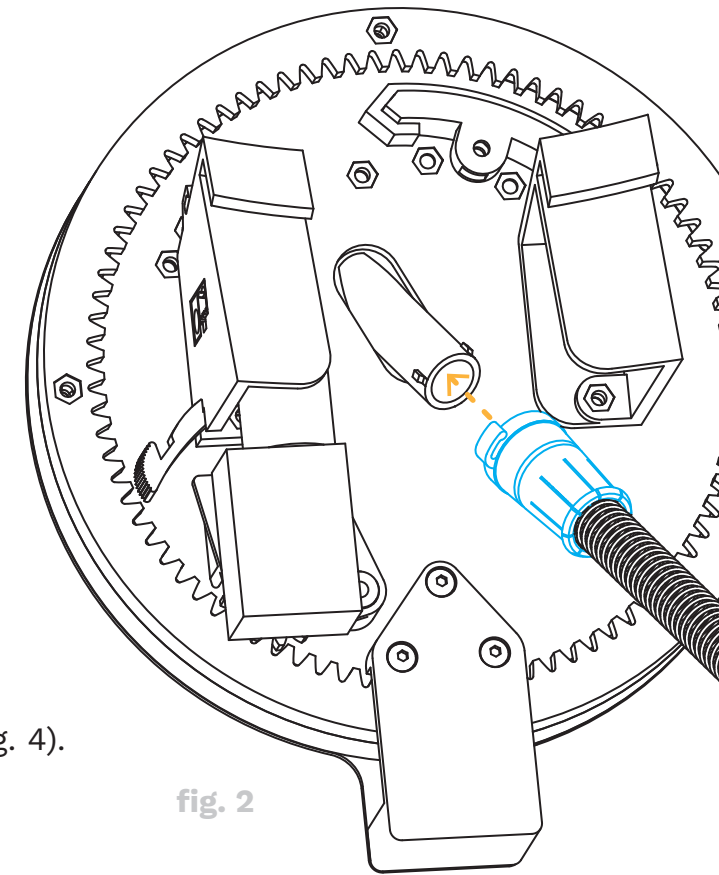

fig. 3

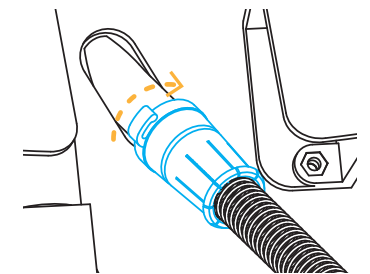
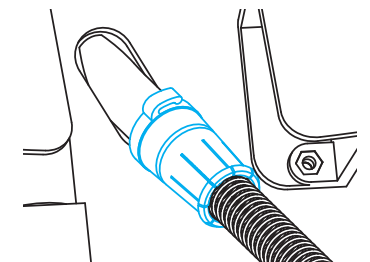

fig. 4



Insert bullet feed die

Insert die into the toolhead. Depending on your setup, you will most likely use station 3 or 4.

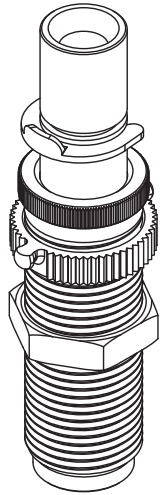
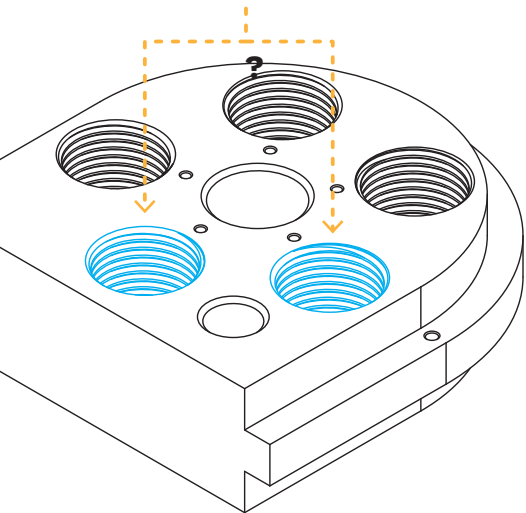

fig. 5



Connect both springs to the hooks on the plastic nut and lower plastic tube holder.

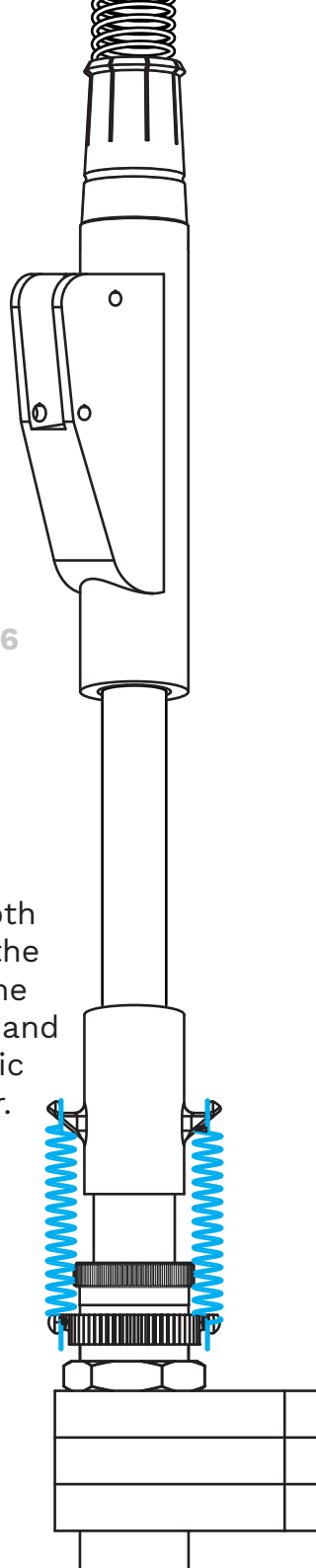

fig. 6

Connect power and sensor cable

Connect the supplied 12V Power adapter to the Bullet feeder through the cable with the switch.

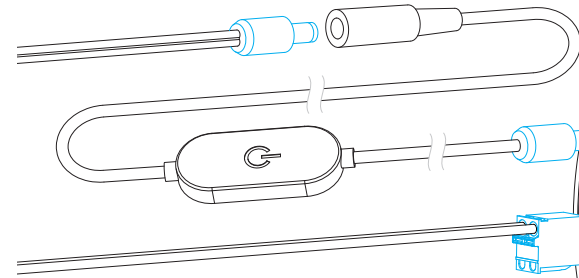

fig. 7

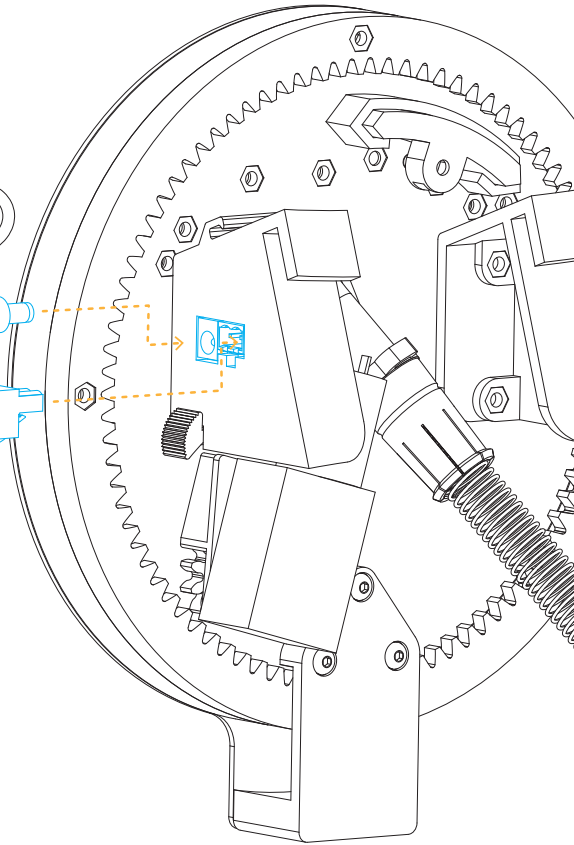
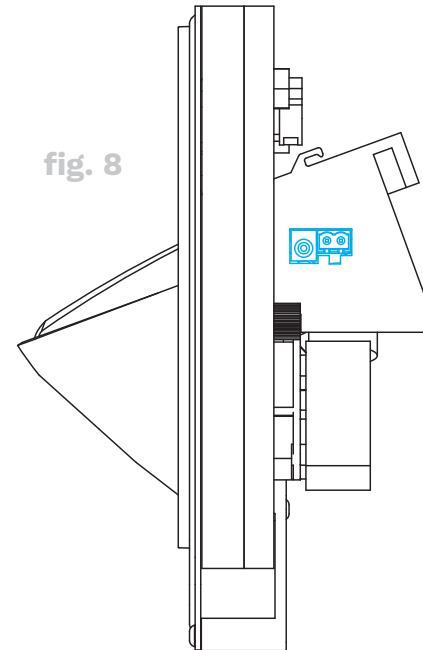

fig. 8



Do not connect the power supply directly to the Bullet feeder.

Connect the sensor cable directly to the Bullet feeder.